

General Presentation
Who we are!



THE AGENDA

CEO Message , Vision & Strategy

Partners & Stakeholders

Understand Failures

Business lines setup

A Spot light on Partners

Dear Valuable Customers and Business associates

*We have incorporated more than 200 years of experiences into **MOT-GEN MEA** In which your call of service has become under a click of a button.*

*There would be many rainy days during operations where your Turbomachinery transformers, motors, and generators are gone beyond the control. Therefore, it has been very demanding to join the forces in a purpose-built organization in order for us to offer our clients a second to none, unprecedented perceived value proposition that eventually maximizes the return on the customer's assets .Together with world best, proven experienced market leaders from the east and west merged on **MOT-GEN MEA**, have one mission, to fix our customer problems Right first time.*

We're experts enough to cover a big range of rotating machines & wide though to extend to the most of the middle east and African countries.

It's nothing but evolution in equipment life assessment, repairing, upgrading, replacing and parts supply.

MOT-GEN MEA the expert eye at your fingertip



**CEO
MESSAGE**

Mot-Gen MEA Corporate MGMT



CEO - Sales Dir.

Eng. Ehab ElNaggar



Factory Director

Eng. Sami Atta



Operations Mgr

Mrs. Ghada Nour



Administration Mgr

Mr. Youssef Atta



**Corporate Mgr
turbo machinery**

Eng. Hatem Sherby



**Corporate Mgr
Alex**

Dr. Yasser Kamshoushy



**Corporate Mgr
Power**

Eng. Youssef Gebaly



**Financial Mgr
Corporate**

Mr. Rasmy

Channel Mgr Tunis

Channel Mgr Egypt

Channel Mgr Morocco

Channel Mgr Iraq

Channel Mgr Cot'd voir

Channel Mgr Saudi

Channel Mgr Pakistani

Mot-Gen Co-founders

CEO. Ehab El-Naggar



BIO

*One of the Globally known rotating machines service leaders, 24 years of techno-management leadership track records. Was heading the MEA region & the global O&G service for a world best service organization for almost 2 decades of time before he runs Mot-Gen MEA.. He has not only accumulated a wealth of knowledge but also earned a solid reputation as a leader since he was globally awarded of being **"the best"** when we talk achievements.*

5 main W.shops, 3 service vans , 10 life assessment hubs were one-side of a long list of accomplishments



Director of board. Sami Atta



BIO

*The first setup of Atta sons in Egypt was in 1947 with a bit of focus on maintaining the construction equipment and related parts. When the pair of brother Sami & Youssef took over, The business grew larger to position Atta sons as **"the largest"** regional machine shop of 21000 sqm to include all to do with machining and dynamic balancing of mostly all heavy equipment and shaft repair techniques*

35 laths, 8 horizontal & 6 vertical hydraulic pistons and 30 ton schenck balancing machines are one side of long list of eqpts.



Mot-Gen MEA Board Vision



The Vision

*Creating our own **iconic brand value** in servicing Customer assets throughout deploying “**The Expert Eye**” strategy to deliver our customer, the best-in-class one of a kind service, that Customer never thought is ever existed*

“The Expert-Eye” is the main corner stone of our holistic strategy

The Strategy

*Incorporating over **200 years** of experiences of local partners, corporate team and world’s best global service organizations, all into **MOT-GEN MEA** one stop shop to make “**the expert-eye** “ nothing but available at a call-distant.*



“Expert Eye” helps customer to
do it right first time

Mot-Gen Mea logo spells it all loudly

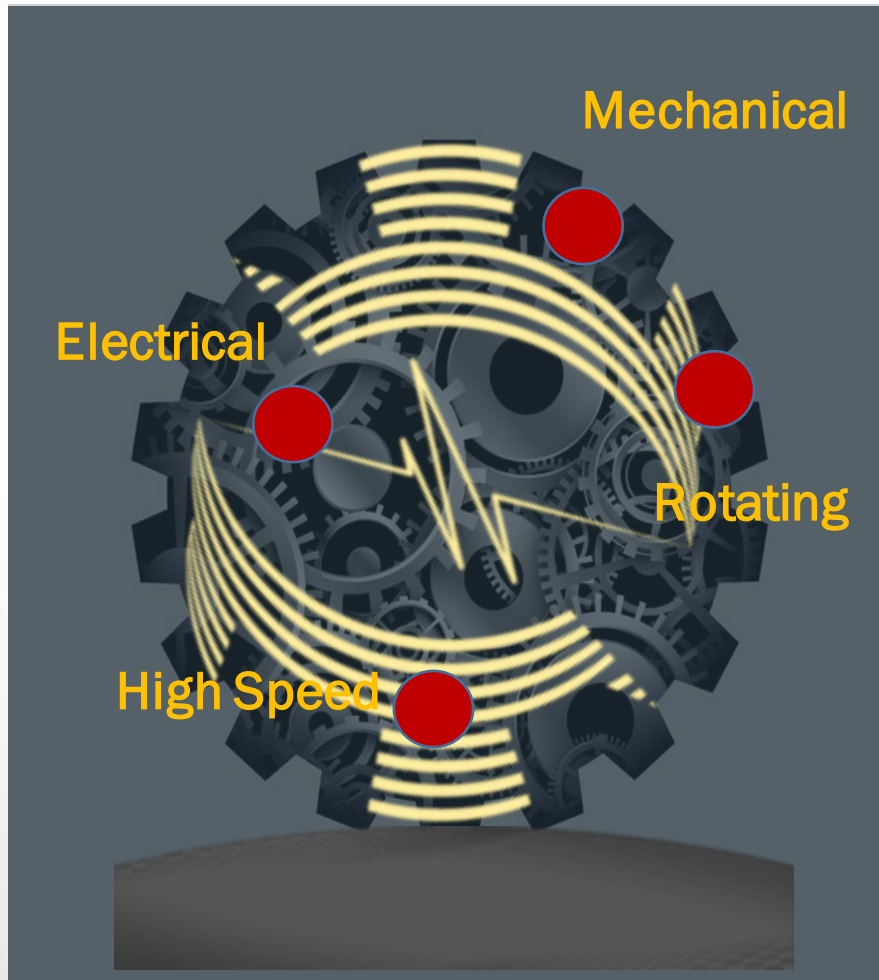

What Mot-Gen MEA and its partners
are good at

*we cover all
Electrical & Mechanical Rotating
equipments with a specialty on
the **high speed** turbomachinery
such as Turbines, compressors
and turbo-generators*



EXECLUSIVE PARTNERS

Mot-Gen MEA is the exclusive Partner of world class, global service org.'s



Zwijndrecht, January 13, 2021

Subj: Official Representation Letter

To whom it may concern,

I, undersigned Ludovic Thybergin, Chief Financial Officer, declare that the company **Mot-Gen MEA, LLC**, located at:
10th El-Hegaz St, Ground Floor, Mir El Gedida, Cairo, Egypt
Registered in Egypt under the number of 157103

...is the exclusive sales representative in the territory of **Egypt** for the company **Maintenance Partners Belgium NV**, located at:
Vishoekstraat 6, Haven 1035
2070 Zwijndrecht
Belgium
Registered in the Belgian registry of Legal Entities under the number 0414.445.663

For the maintenance, repair and reconditioning of all electrical and mechanical rotating machines (generators, turbines, turbocompressors, reciprocating compressors and expanders/companders).

Maintenance Partners Belgium NV commits to support **Mot-Gen MEA, LLC** with technical services for the equipment listed above (including skilled manpower, testing equipment, engineering and state of the art workshops), this allows **Mot-Gen MEA, LLC** to offer clients in Egypt a world-class service level.

Ludovic Thybergin
Ludovic Thybergin,
Chief Financial Officer

Maintenance Partners Belgium nv
Site Zwijndrecht
Vishoekstraat 6 - B-2070 Zwijndrecht
Tel +32 (0)3 744 15 01. Fax +32 (0)3 744 15 02
BTW BE 0414.445.663

www.maintenancepartners.com

1974 Antwerpen
VAF BE 0414.445.663
WAN BE02 4324 1029 4709
INC 197408050

PARTZSCH
ELEKTROMOTOREN

AUTHORIZATION LETTER

This letter is being issued to declare that
MOT-GEN MEA, LLC - Egypt
10th El-Hegaz St., Ground floor, Mir Elgedida
Cairo, Egypt

Registered in Egypt as a Legal Entities under the number 157103
Represented by General manager : Ehab mahmoud Elnaggar

is our exclusive agent and is solely authorized
to represent products, services and solutions of our company

PARTZSCH Group of Companies
Daniel-Wilhelm-Beck Street 13, 04720 Döbeln, Germany
Registered in the German Registry of Legal Entities under the number HRB 32817

In Egypt and valid from
NOVEMBER 01, 2020

The following are activities listed:

- Components for electrical machines, coils, windings, cores, etc.
- Service repair and maintenance on motors and generators
- On-Site service on air cooled designed machines incl. turbo generators
- Reproduction of old machines
- New synchronous Generators

We commit to provide MOT-GEN MEA, LLC - Egypt with complete technical support in terms of quality products, skilled manpower, test equipment, quality execution, analytical expertise and world class facility required for above products and services, to be able to provide comprehensive support to customers in Egypt, with international quality as expected from global service providers.

Authorized signatory
Sven Köhne
Sven Köhne
Authorized officer / Geschäftsführer

PARTZSCH Elektromotoren GmbH
Daniel-Wilhelm-Beck-Strasse 13
04720 Döbeln
Germany
E-Mail: info@partzsch.de
www.partzsch.de

REPRESENTATION
Geschäftsführer: Sven Köhne
E-Mail: info@partzsch.de
www.partzsch.de

POWER ELECTRONICAL
High Voltage Dielectric Diagnostics

AUTHORIZATION LETTER

This letter is being issued to declare that
MOT-GEN MEA Co., LLC, Egypt
is our exclusive agent and is solely authorized
to represent products and solutions of our company

Power Electrical, India
In Middle East and Africa region and valid from
December 01, 2020

The following are activities listed:

- Condition Monitoring/Testing/Residual Life Assessment of Electrical Rotating Machines – HT Motors / Generators of any make.
- Dry-ice cleaning, dry out and varnishing (Cleaning) Services for Electrical Rotating Machines – HT Motors / Generators of any make.
- Condition Monitoring/Testing/Residual Life Assessment of Oil filled Power Transformers of any make and configuration.
- Installation and Maintenance Tests of MV Cables from 6.6 to 33 kV.
- Product sale for diagnostic equipment manufactured/marketed by Power Electrical.

We commit to provide MOT-GEN MEA Co., LLC with complete technical support in terms of skilled manpower, test equipment, quality execution, analytical expertise required for above products and services, to be able provide comprehensive support to customers in Middle East region, with international quality as expected from service providers.

For Power Electrical, India
Ameet Chughule
Ameet Chughule

For MOT-GEN MEA Co., LLC, Egypt
Ehab El-Naggar
Ehab El-Naggar

D-24, MCC-Arabad, Hoshi-16, MH, India
+91 253 80228758
info@powerelectrical.com
www.powerelectrical.com



**Mot-Gen
Co-Founder**



UNDERSTAND FAILURES

Mot-Gen role, is to inspect, discuss and repair what went wrong causing the failure



Compressor rotor failure



Turbine blades failure



Transformer failure

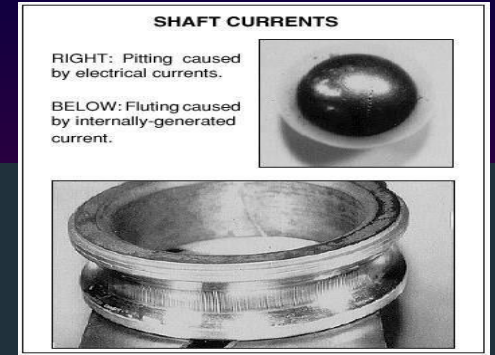

Bearing failure



Rotor Rubbing failure

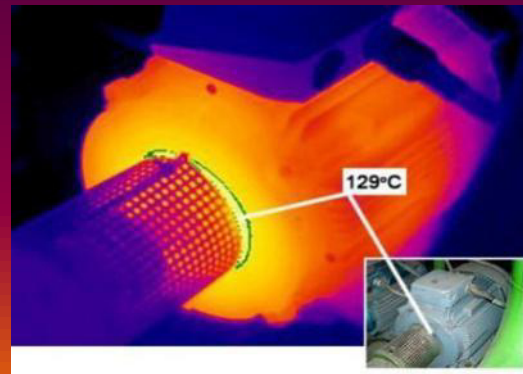

Overheating failure



Coils ground failure



PD signs of failure



BUSINESS LINES STRUCTURE

“ The Expert Eye “ kicks in!

Mot-Gen has 4 service Product lines structure



Rotating machines Motors , pumps,

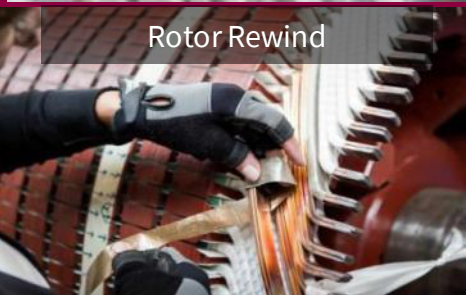
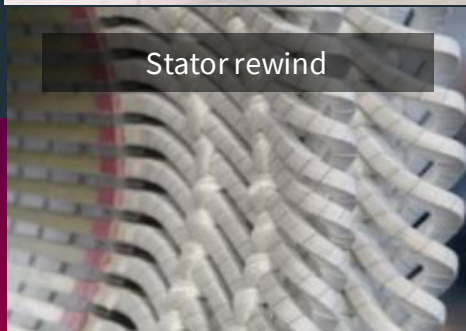
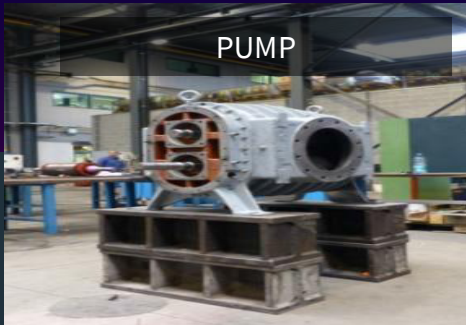

Testing & condition assessment

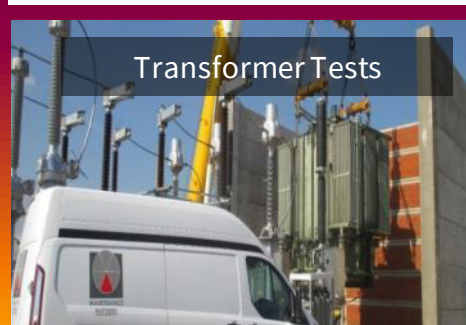
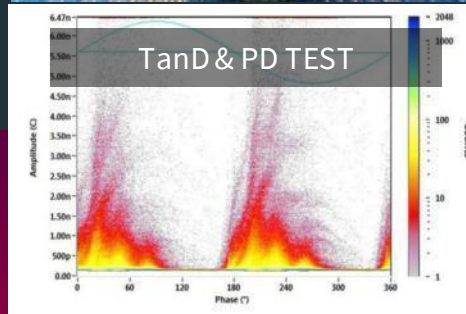

New products and parts



Turbomachinery Turbines & compressors



Repairing would need to join forces

The Expert Eye :MPB / PARTZSCH / Atta Sons /PE



One-to-one replacement



Salient pole rewind



Slip ring Rotor Rewind



MV Stator Rewind



S. turbine repair



Compressor repair

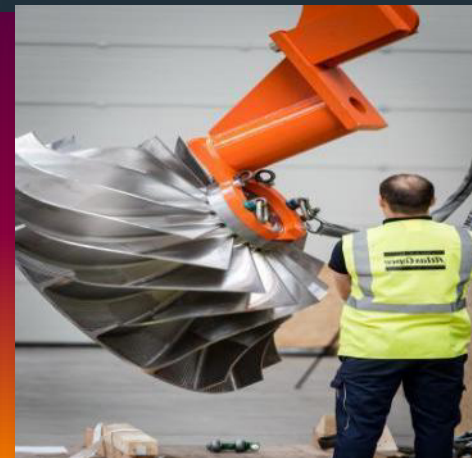

Parts Reverse Eng.



Vacuum balancing

Division of work matrix between Mot-Gen MEA and the Partners

MPB : Maintanance Partners Belguim

ATTA: Atta Sons for machining, EGY.

PE: Power Electrical for testing& life assess

PARTZSCH : Coils supplier Germany

Business line / Scope of work	BL : Rotating	BL : Turbomchinary	BL : Testing & life assessment	BL : New machines/Coils
Field Service	☐ Mot-Gen/MPB	☐ Mot-Gen / MPB /PARTZSCH	☐ Mot-Gen / PE	N/A
Workshop Mechanical	☐ ATTA / MPB	☐ ATTA/ MPB /PARTZSCH	☐ MPB	N/A
Workshop Electrical	☐ MPB /PARTZSCH	☐ PARTZSCH/ MPB	☐ MPB /PARTZSCH	N/A
Engineering New parts New machine	☐ MPB /PARTZSCH	☐ MPB	☐ PE/PARTZSCH/ /MPB	☐ MPB /PARTZSCH



**Spot light of Partners activites
“ The Expert Eye “ kicks in!**



Machining and balancing at Atta Sons plant



Atta Youssef Sons is one of the largest integrated equipment service centers in terms of maintenance with a highly skilled work team and provide the original spare parts suitable .. Taking into account the factor of time and achievement

- *More than 70 years of machining & balancing experience.*
- *Purpose built facility with state of art equipment resulted in customer appreciation being the preferred Heavy duty machine shop and manufacturing plant in Egypt*
- *160 Technicians including foremen*
- *100 tons lifting capacity.*
- *21000 halls area at Cairo-Ismalia road.*
- *16 no. of laths and boring machines.*
- *8 horizontal & 6 vertical hydraulic pistons*
- *30 ton schenck balancing machine & 2 others fit for purpose*



MACHINING & BALANCING AT ATTA SONS

SHARE HOLDER AND FOUNDER OF MOT-GEN MEA



BALANCING



WELDING



MACHINING



TURNING

Services

- > Undercarriage Maintenance
- > Heavy Equipment Maintenance
- > Crushers Maintenance
- > Welding
- > Dynamic Balance
- > Lathing

ONE OF A KIND SERVICE PLANT

PARTNERS & CLIENTS OF ATTA SONS



HERCULES[®]
SEALING PRODUCTS

VTRACK
BY PASSINI

COMEC 



Over Time, In Every Machine

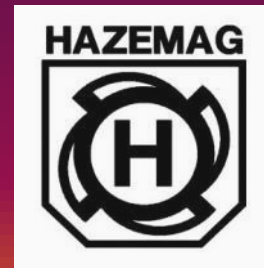

BYG



A Spot light of Partners activities “ The Expert Eye “ kicks in!



Power Electronical is a global leader in motors, Gen's, transformers and cables diagnosis ,analysis & Life assessment



POWER ELECTRONICAL
High Voltage Dielectric Diagnostics

	Rotating Machine Field Services		D-24, MIDC-Ambad, Nasik-422010, MH, India
	HV/EHV Equipment Testing		+91 253 6602387/88, 2383271
	Transformer Oil Testing Lab		+91 98222 12422
	Electro Technical Calibration Lab		contact@powerelectronical.com
	Dielectric Diagnostic Products		www.powerelectronical.com

Dielectric Diagnostic Products www.powerelectronical.com

Electro Technical Calibration Lab contact@powerelectronical.com

Transformer Oil Testing Lab +91 98222 12422

HV/EHV Equipment Testing +91 253 6602387/88, 2383271

We start the journey from the machine failure analysis station in Mot-Gen



Why diagnose?

Single Test or Package ?

Which Tests ?

Why ?

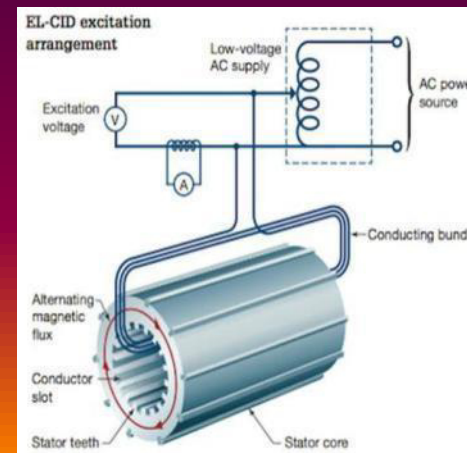

Site testing incorporated with our partner Power Electronical



LIFE ASSESSEMENT FOR INSULATION SYSTEM (RLA) Data base of 15000 motors Generator &Transformer

- PE uses best in class test equipment by reputed brands with superior software to guarantee safe tests and accurate results.
- PE provide better technologies than conventional tests from standards or guidelines (eg. PDCA/NLIC)
- PE has trained and experienced team
- PE has a backend expert analysis team
- PE implies best services at affordable rates
- One stop shop for diagnostic assessment of all your electrical assets (generator, LT/HT motors, transformers, LA, CB,CT/PT relays.)

Global clients of Power Electronical



AND MANY MORE.....

AND MANY MORE.....



Spot light on Partners activities “ The Expert Eye “ kicks in!



MPB Workshop Belgium



- 20 000 m² total floorspace
- Overhead cranes up to 110.000 KG
- Lathes
- Milling machines
- Horizontal bore
- Welding equipment
- Coating applications
- Climate controlled measuring room
- 3D measuring equipment
- Atos triple scan
- Material analyser
- Welding robot
- Electric test facilities
- Non and destructive test equipment
- Glass blast facilities - 8000 x 3000 x 3000 mm

MPB , The largest repair and engineering Service Facility in Europe



- *Over 20000 sqmt*
- *Shop and field activities*
- *Standardization*
- *All brands*
- *All rotating machines*
- *Rewinding E motors*
- *Welding repairs*
- *Major and minor overhauls*
- *High and low speed balancing*
- *Part refurbishment*
- *Parts supply:*
- *O.E.M or by reverse engineering*
- *Revamps and upgrades*
- *Failure analysis*
- *Vibration analysis*
- *Reliability audits and programs*
- *Second hand equipment*
- *New equipment*



MPB , field service



Our highly skilled field service employees provide services such as minor and major overhauls, including commissioning and start-up assistance. This service can be performed on scheduled or non scheduled maintenance.

Our field service team is fully equipped with:

- Tool and hoisting containers
- Hytorc
- Laser alignment
- Condition monitoring
- Field balancing
- 3D scan
- Atos triple scan
- Non destructive testing

MPB , Engineering capabilities



MP's Engineering team consists of 30 specialists

- Material Engineer
- Design Engineer
- Process Engineer
- Technical Specialists (Electrical, Mechanical, Welding & Diagnostics)
- CAD Drawers
- Project Managers
- Reliability team (vibration, electrical analysis, infrared, ultrasound, dielectric measurements)
- MP connectivity
- P4A



Main capabilities

- 3D Scanning of spare parts
- Re-engineering of spare parts
- Remodeling damaged spare parts
- Improving of efficiency (redesign & upgrades)
- Improving of durability (materials & upgrades)

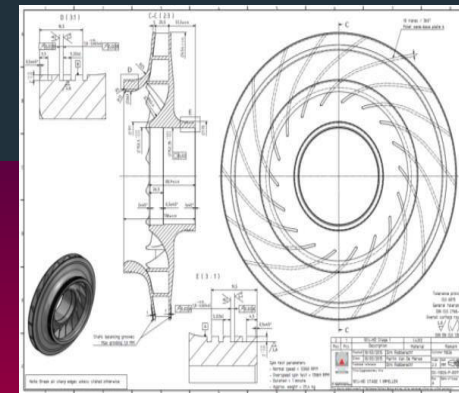

GLOBAL CLIENTS OF MPB





Spot light of Partners activities
“ The Expert Eye “ kicks in!



Partzch , the largest coils, motor Parts, replica motors in Europe



Today, PARTZSCH has become Europe's largest manufacturer-independent repair plant with more than 600 employees and 40,000 m² of production space.



We install and supply all coils up to 250 MVA from PARTZSCH



PARTZSCH produces from components to
Whole machine in one place

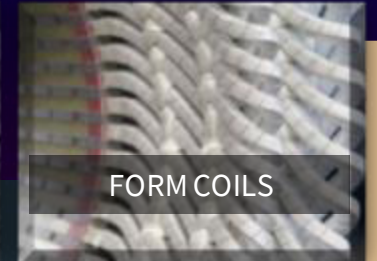

Partzsch close up for the coils production

Using robot for the roebel bars

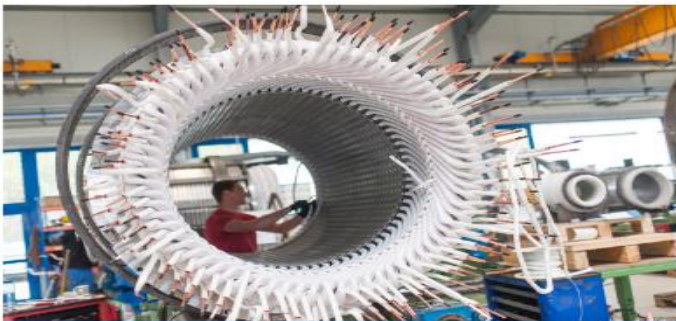
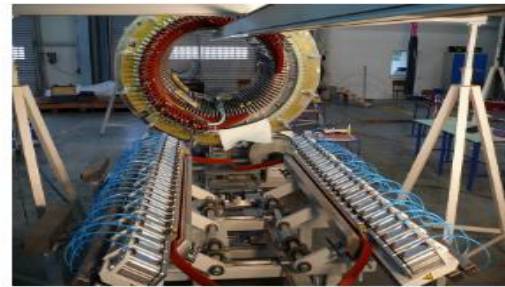
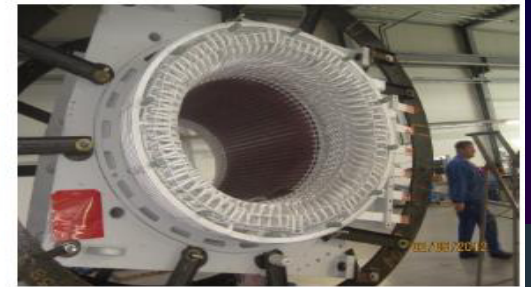

Stator windings



Rotor windings



Special windings

Partzch , reproduction of 1 to 1 large motors & Gen.'S replacement With higher efficiency



Depending on the repair expenses or the availability of spare parts in some cases machines are no longer worth repairing. And for customized electric motors there is usually no alternative in place.

With PARTZSCH you can benefit from an identical reproduction of your electric machine, regardless of age and type. You can thus receive a completely identical new machine in exchange for your existing machine. The reproduction is realized on the basis of existing drawings / documentation or the temporary provision of a sample machine.

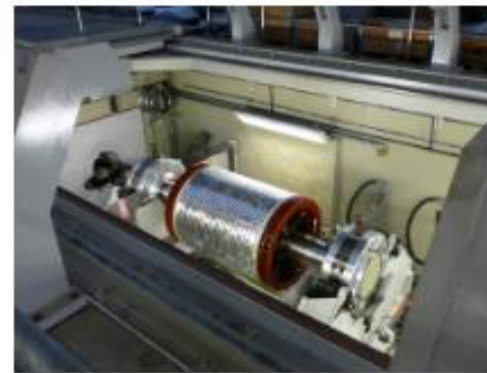
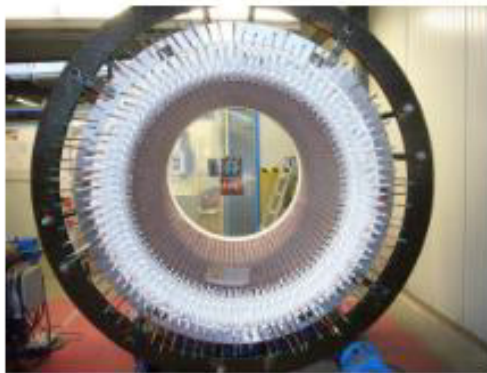

Partzch , the largest capacity in Europe

Testing – vacuum balancing – lamination stacking..etc



ELEKTROMOTOREN



PYROLYSIS

Temp. up to 400°C
Length up to 5,50 m
Capacity up to 50 t



TEST FIELD POSSIBILITIES

electrical (AC/DC),
Mechanical test
Machine test,
Sheet metal package test,
Special tests



IMPREGNATION

Polyesterimide resin
Epoxy
Vacuum-Pressure
process,
Current-UV



HIGH SPEED BALANCING AND SPIN MACHINE

Rotor weight up to 32 t
Length machine bet 8000
mm

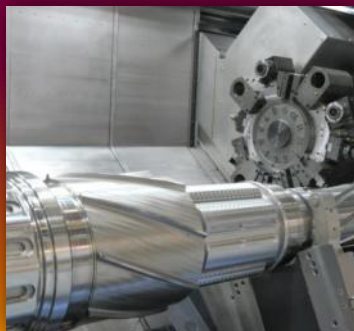

MECHANICAL PROCESSING

Components, assemblies,
complex machine parts



ON-SITE SERVICE FINDINGS/ REPAIR

Repair up to 120 t piece
weight
Repair of all electrical
and mechanical components

Partzch , field service operation for large generators up to 250 MVA



ELEKTROMOTOREN

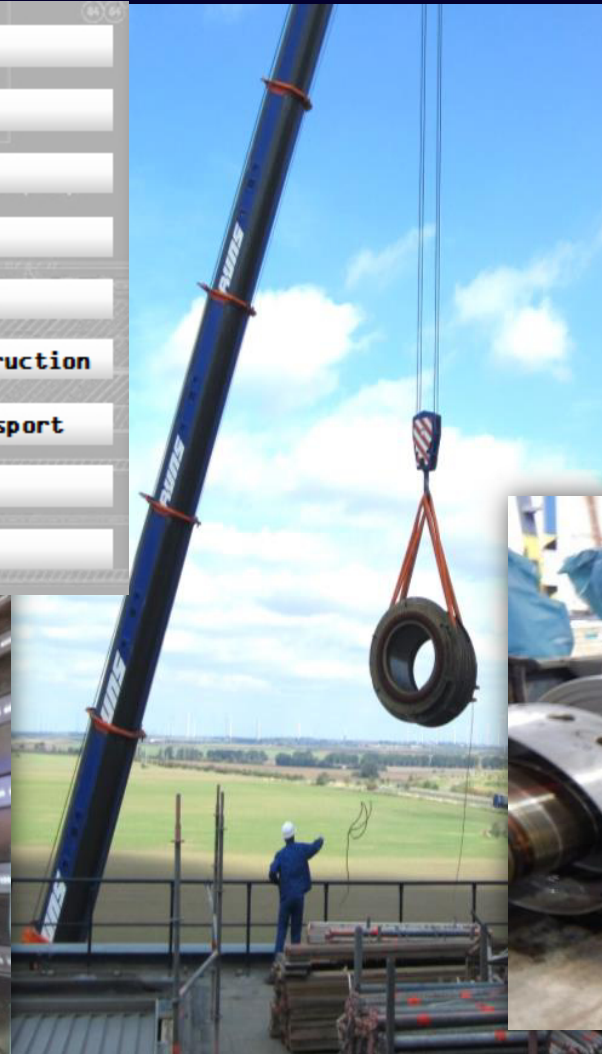
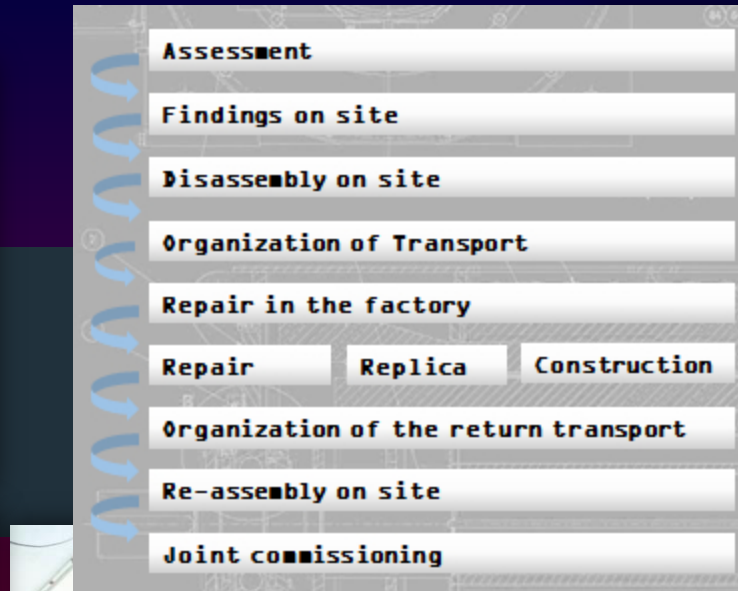

International on-site service for generators up to 250 MVA - regardless of brand and make

Partzch , turbo generator full picture

Roebel bars is a top class service

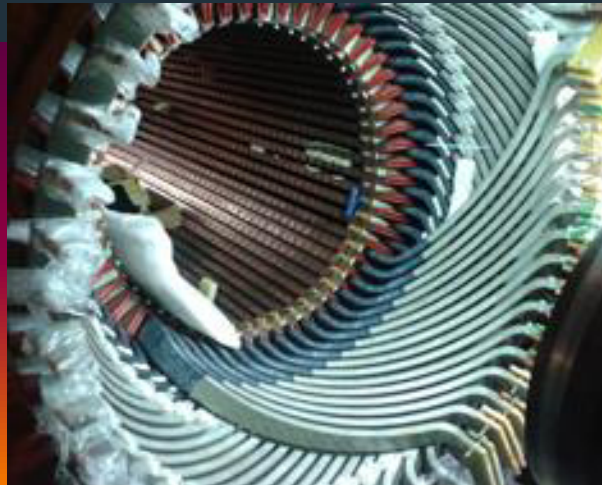
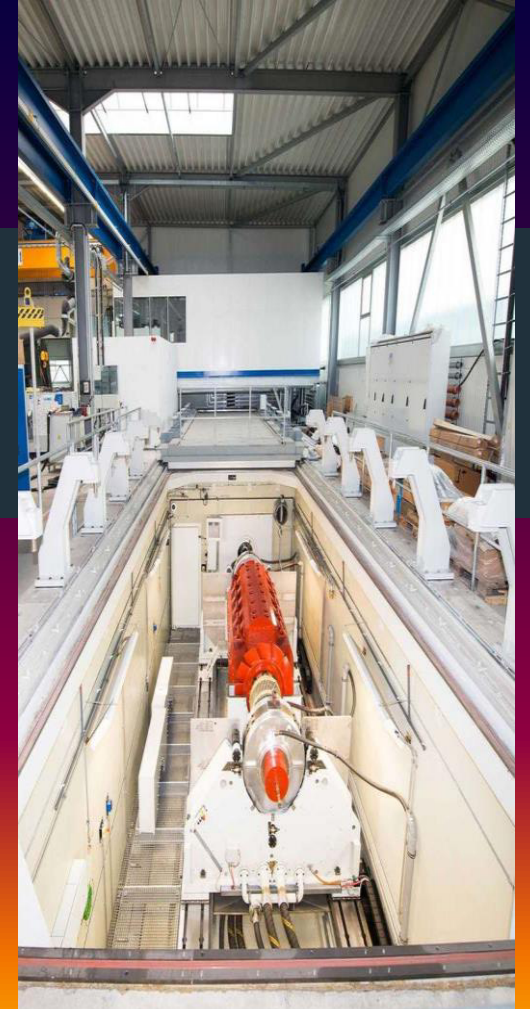
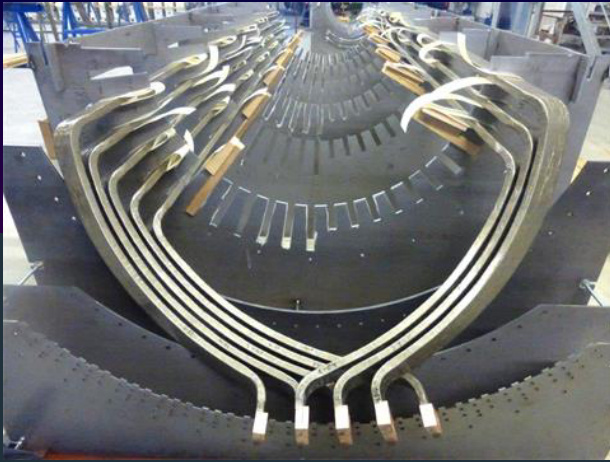

GLOBAL CLIENTS OF PARTZSCH

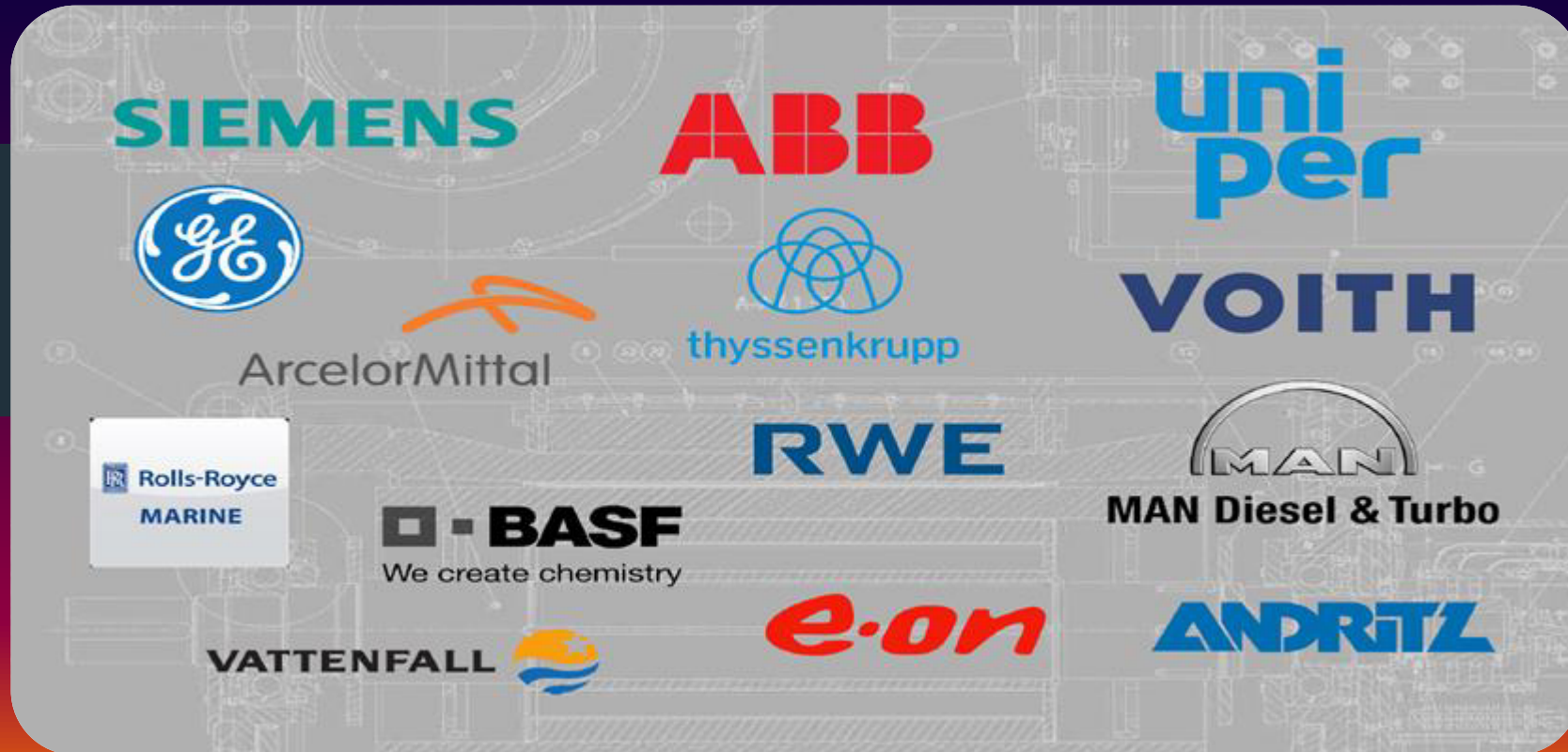



Mot-Gen MEA LLC

Thank you